

(HR Issue)



(, LHC6688@cheonan.ac.kr)

AGENDA



1. 가
2. BSC
- 3.

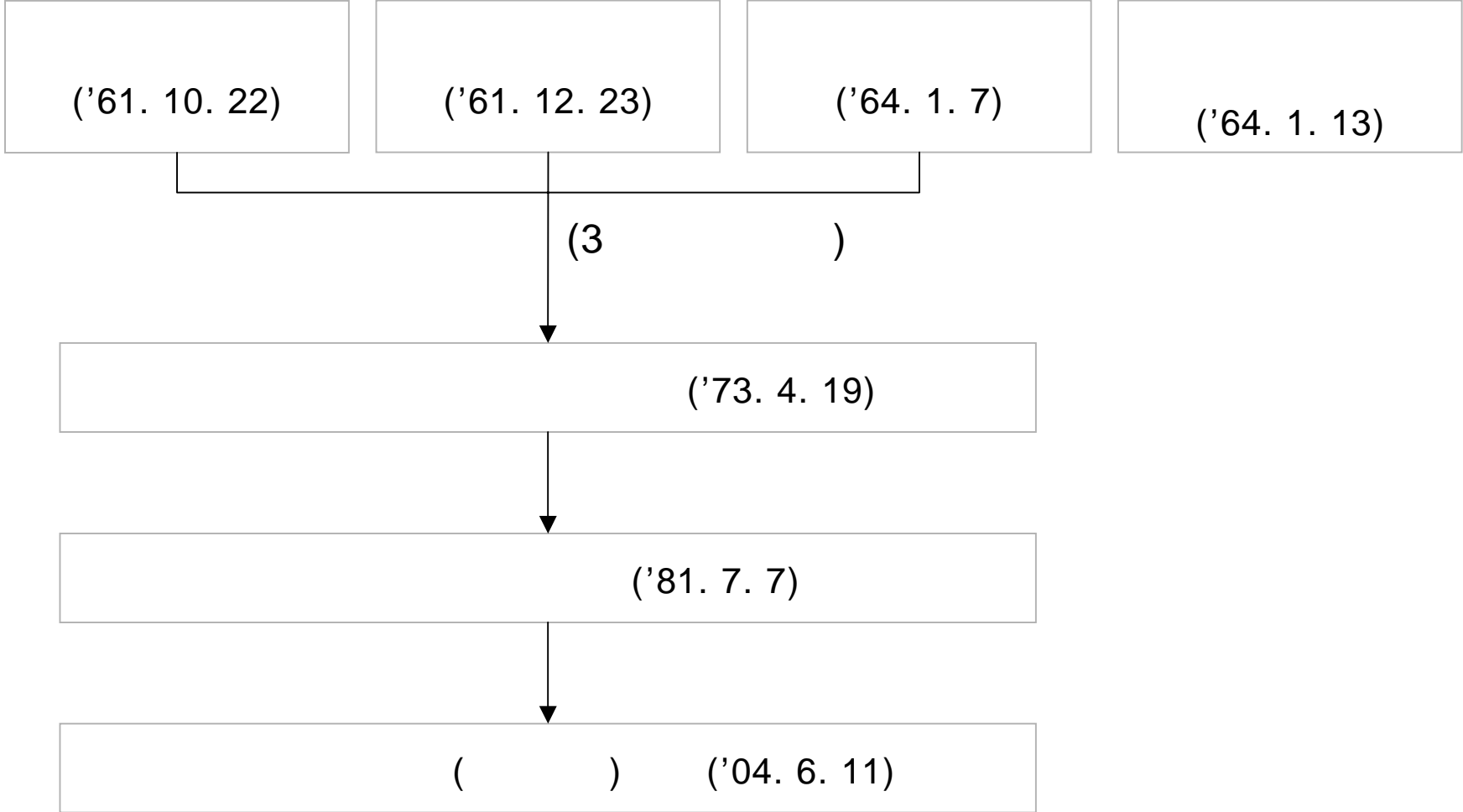

가

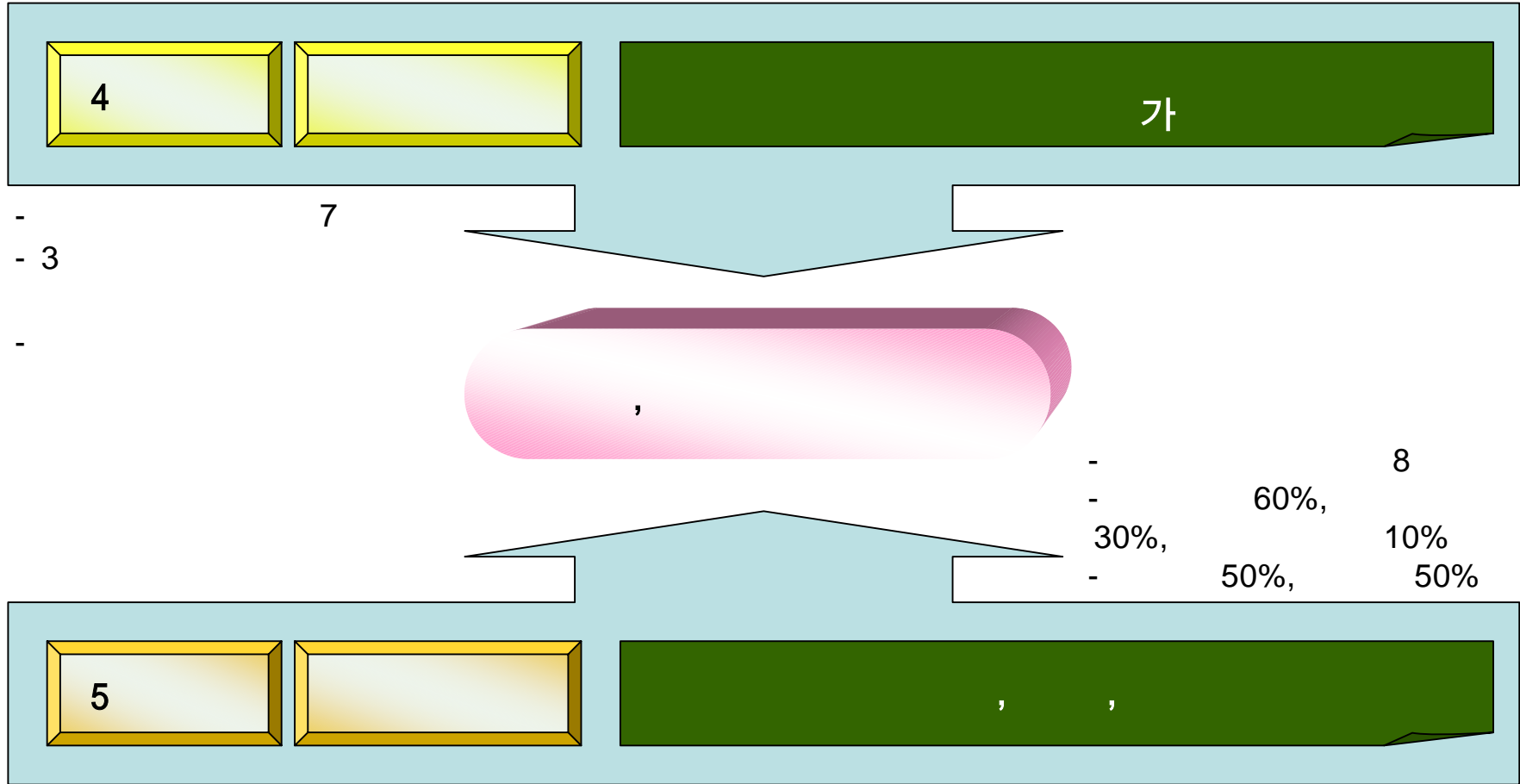

: (2005. 4)

• 가. 가 “ ” 가 “ ”
 가(4)” “ 가(5)”

→ .(4)

→ 가 MBO

• . 가 4 1
 5 (5 , 9)

• . 가 3 가 2
 1 (5 , 15)

• . 가 20% , 10%
 가 (15)

→ 가

• . 가 , 가
 가 (18 , 19)

→ 가 (procedural justice)

AGENDA



1. 가
2. **BSC**
- 3.

()

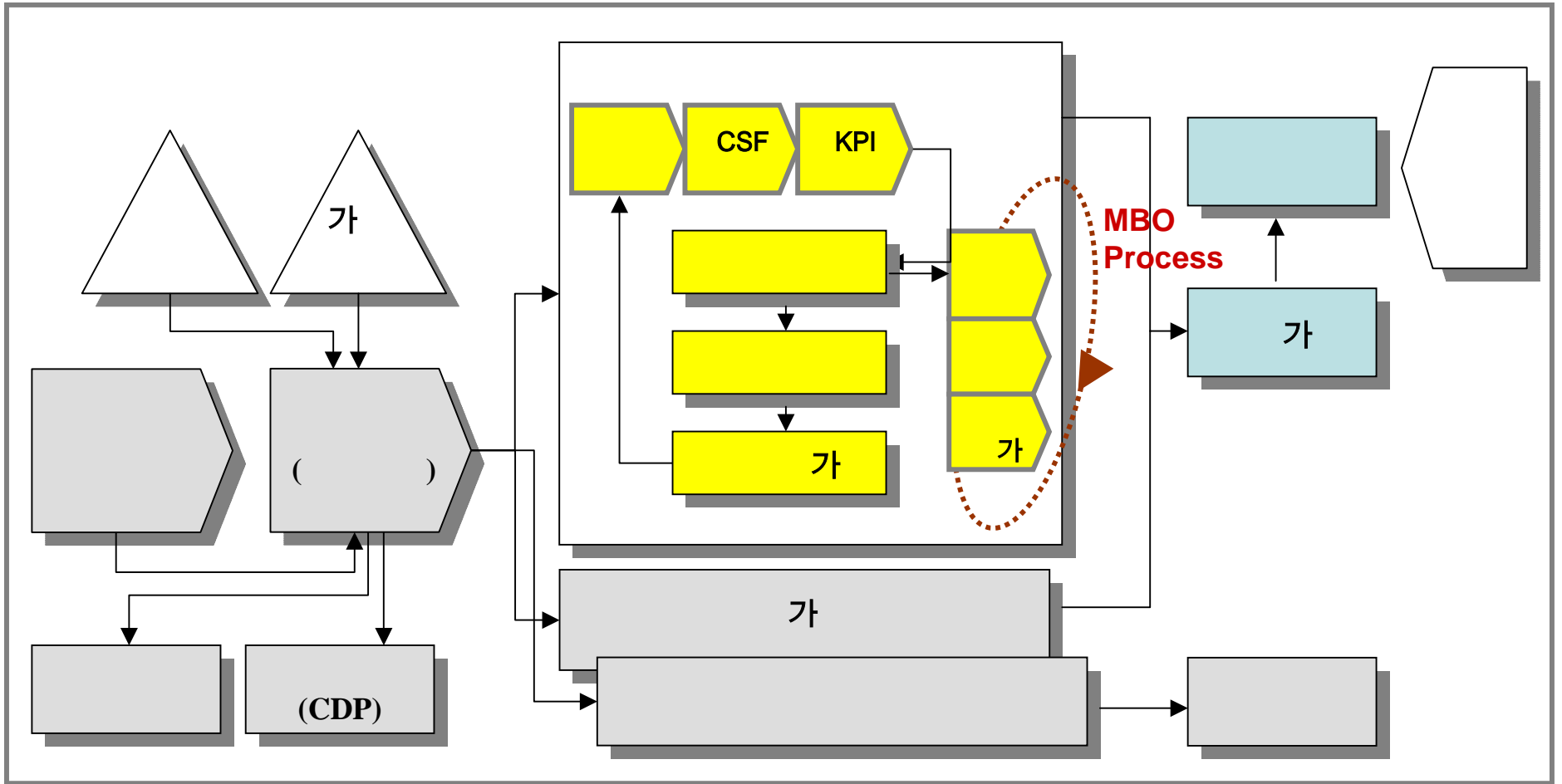

:

, 2005

(BSC)

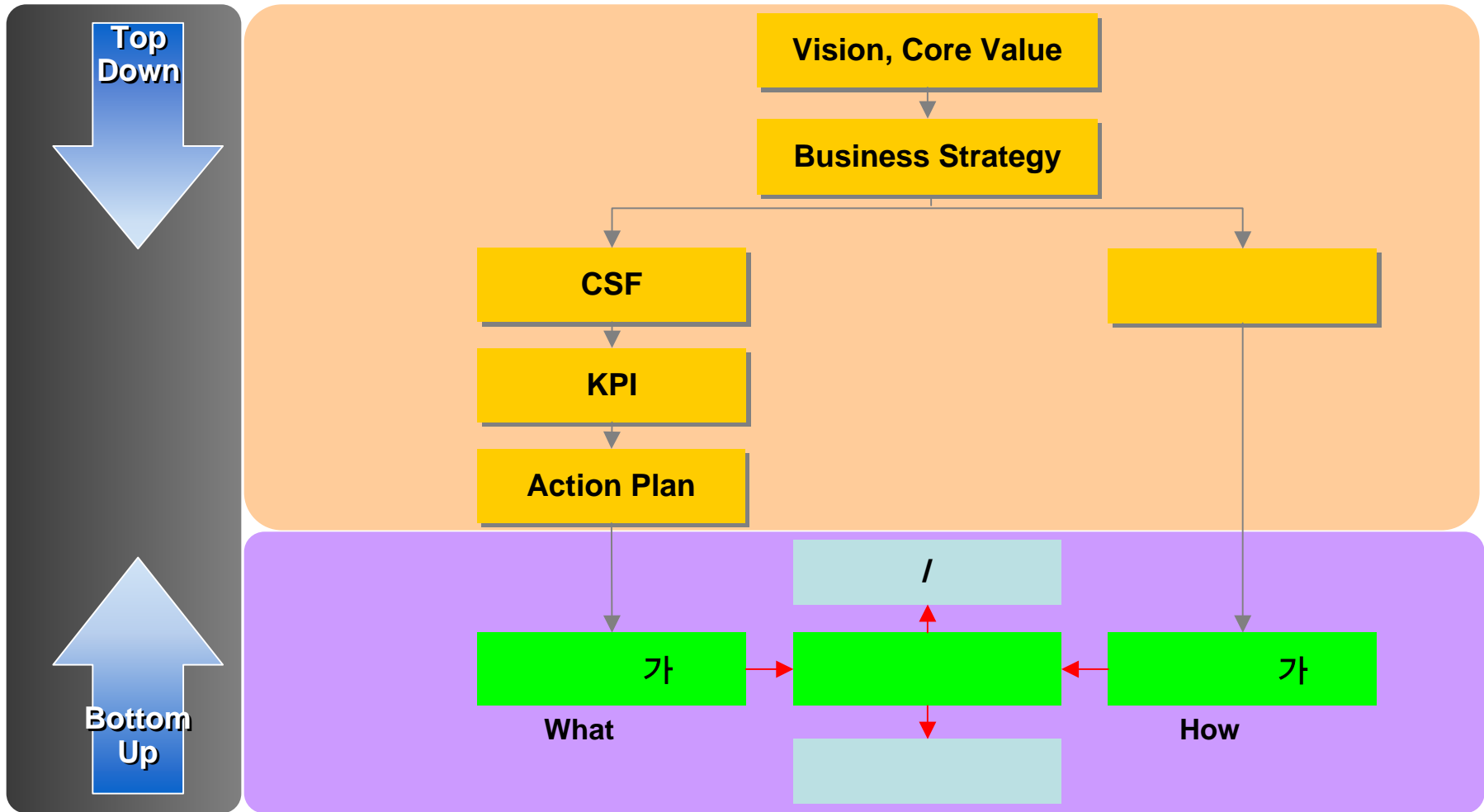

: ()KPI

- KPI KPI 가

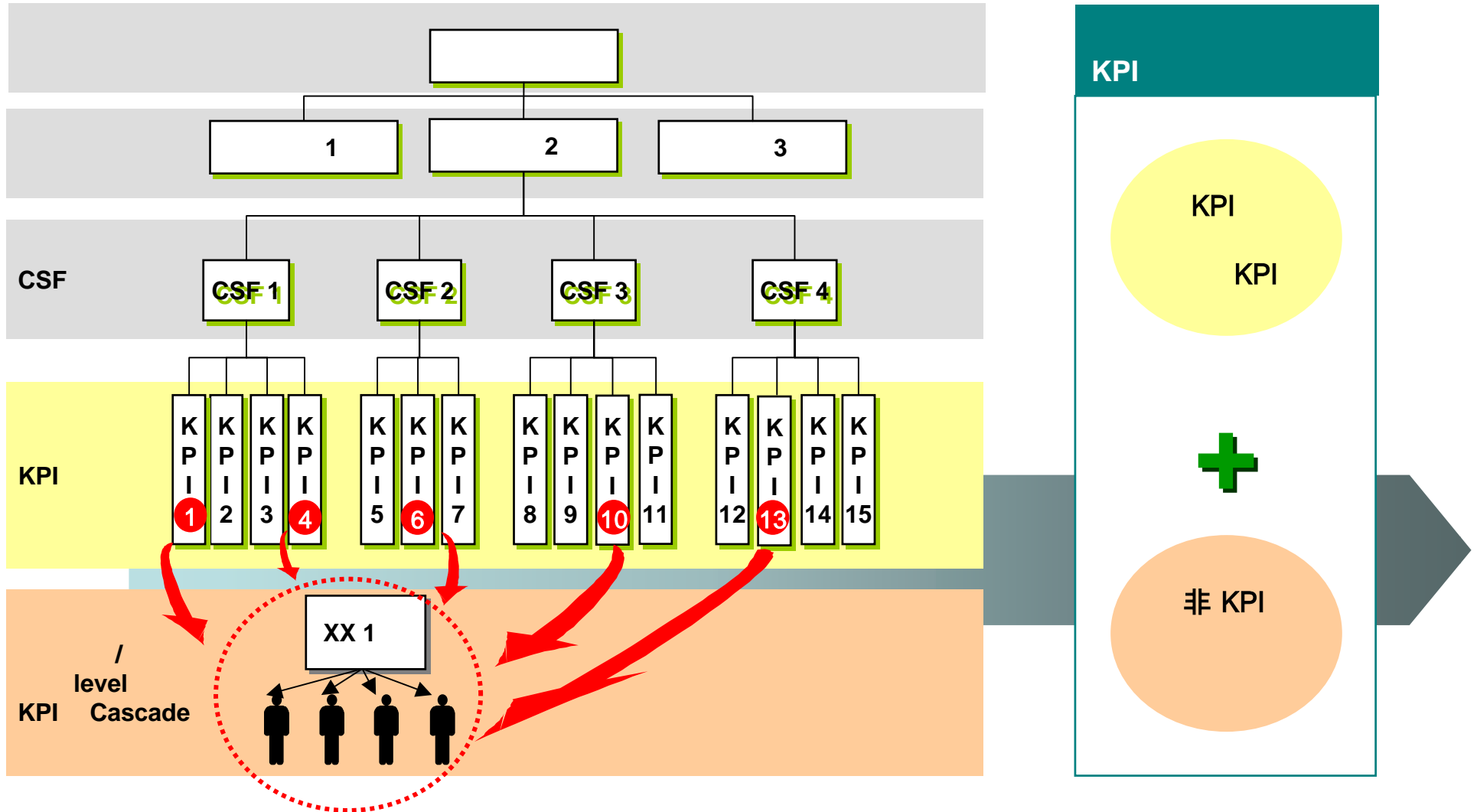

BSC

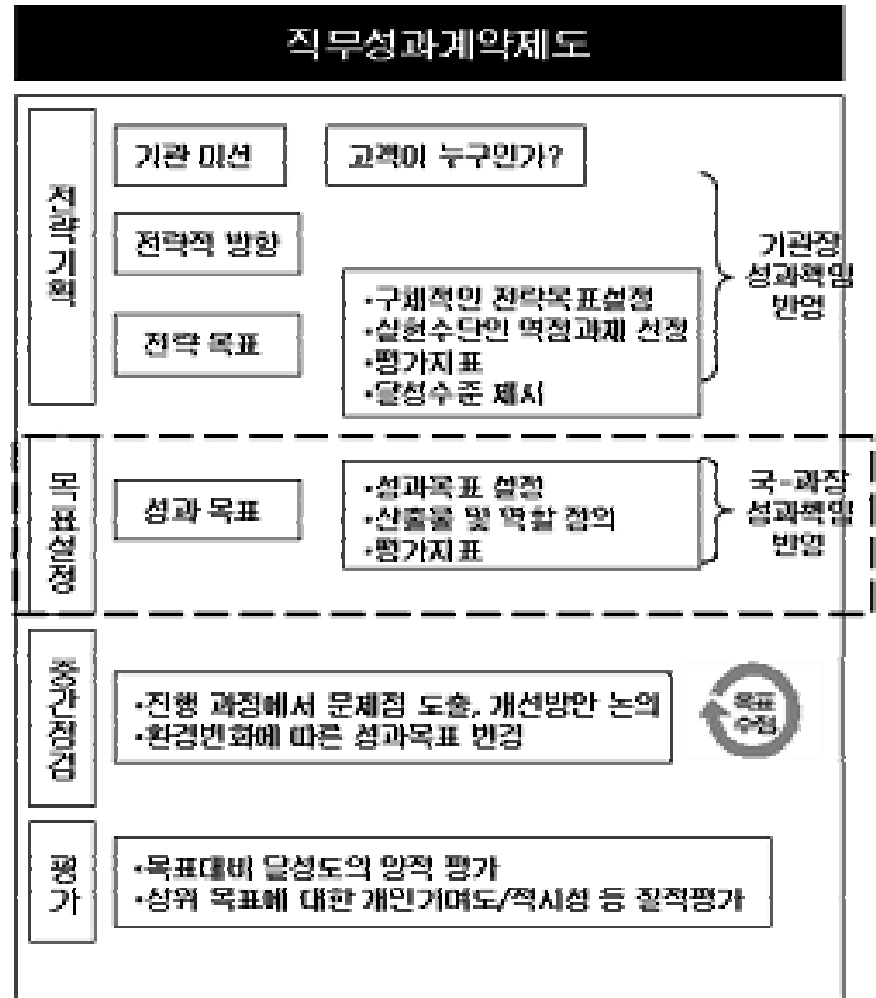
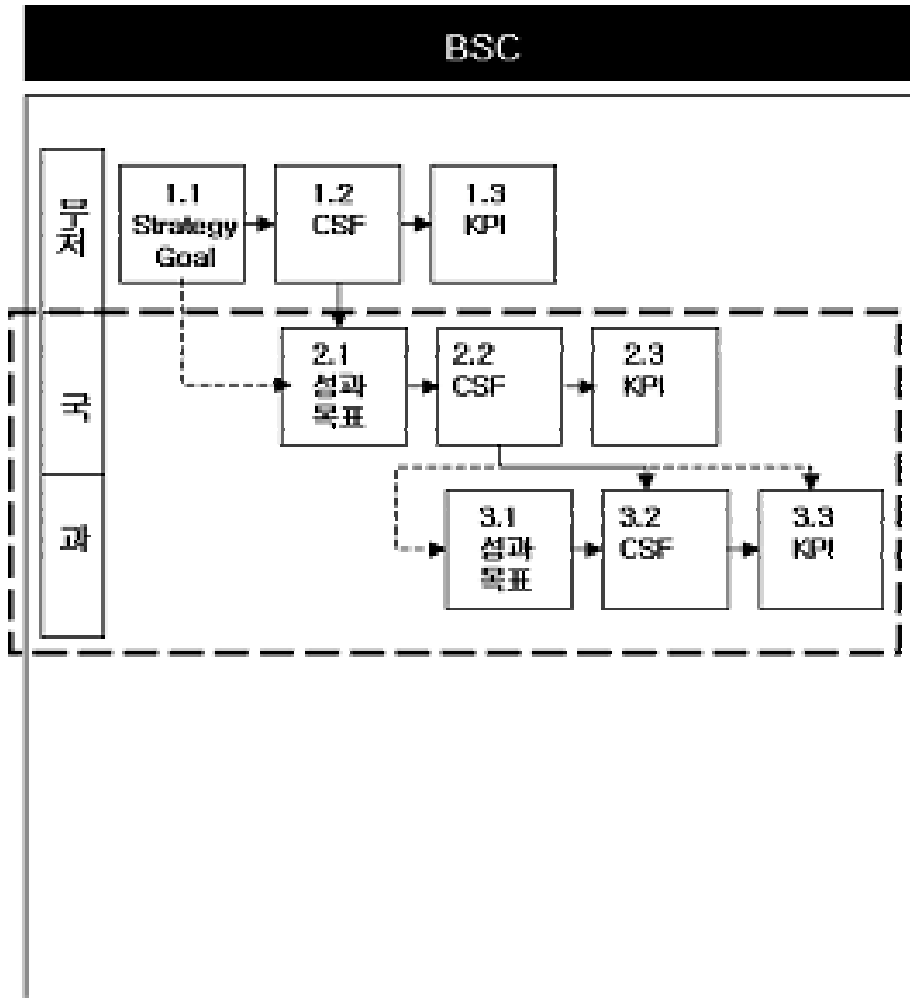

: , 2005

2004 12 BSC : BSC

AGENDA

1. 가
2. BSC
- 3.



