

2003. 4. 12.

| | | |
|----|-------|----|
| 1. | | 1 |
| 2. | | 2 |
| 3. | | 13 |
| 4. | | 15 |
| 5. | | 16 |
| 6. | | 19 |
| 7. | | 21 |
| 8. | | 22 |

1.

가 (G2B)

○ 11

○

(OnBID)

○ 2002 1

KAMCO가

○ ‘ ,

○ 가 .

(2002 - 19 , 2002.12.6)

2.



- 1962. 4. 6 :
- 1966. 8. 3 : _____
- 1982. 4. 6 : 가 _____
- 1984. 2. 1 : • _____
- 1996. 6.15 : _____
- 1997. 8.22 「 _____ 」
- 1997.11.24 : ()
_____)
- 1999. 4.30 : ()
- 1999.12.31 :
(,)

-
-
-
-
-
-
- : 1
- : 1,400

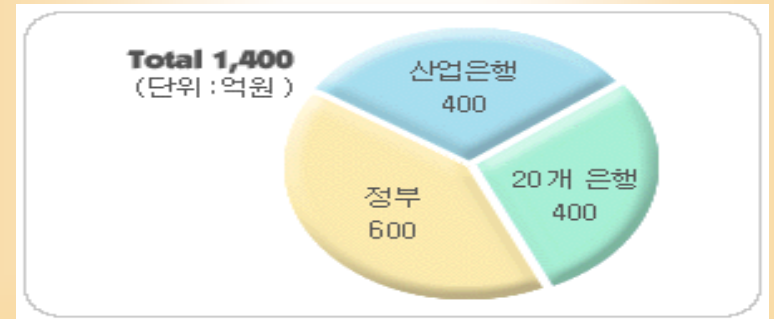

2.



- ✓
- ✓
- ✓

-

- ✓
- ✓
- ✓
- ✓

,

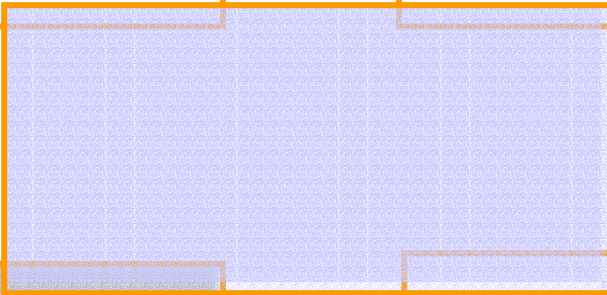

- ✓

-

- ✓ 高
- ✓ 低

- /

- ✓
- ✓
- ✓

2.



- : 공매자산처분 E-마켓플레이스 구축 (브랜드명 - OnBID)
- : 2002.1~ 2002.12
- : 2002. 7월
- : 2002.. 10월~
- : 2002. 12월~

- 공공기관 : 정부기관, 지방자치단체, 정부산하기관, 공기업 등
 - 민간기관 : 금융기관
- : 국유재산, 체납압류재산(국세 및 지방세),
공과금압류재산,비업무용자산, 유입자산 등
- : 매각 및 임대(대부)
- : 공고등록 및 조회, 매물검색 및 조회, 전자입찰

2.

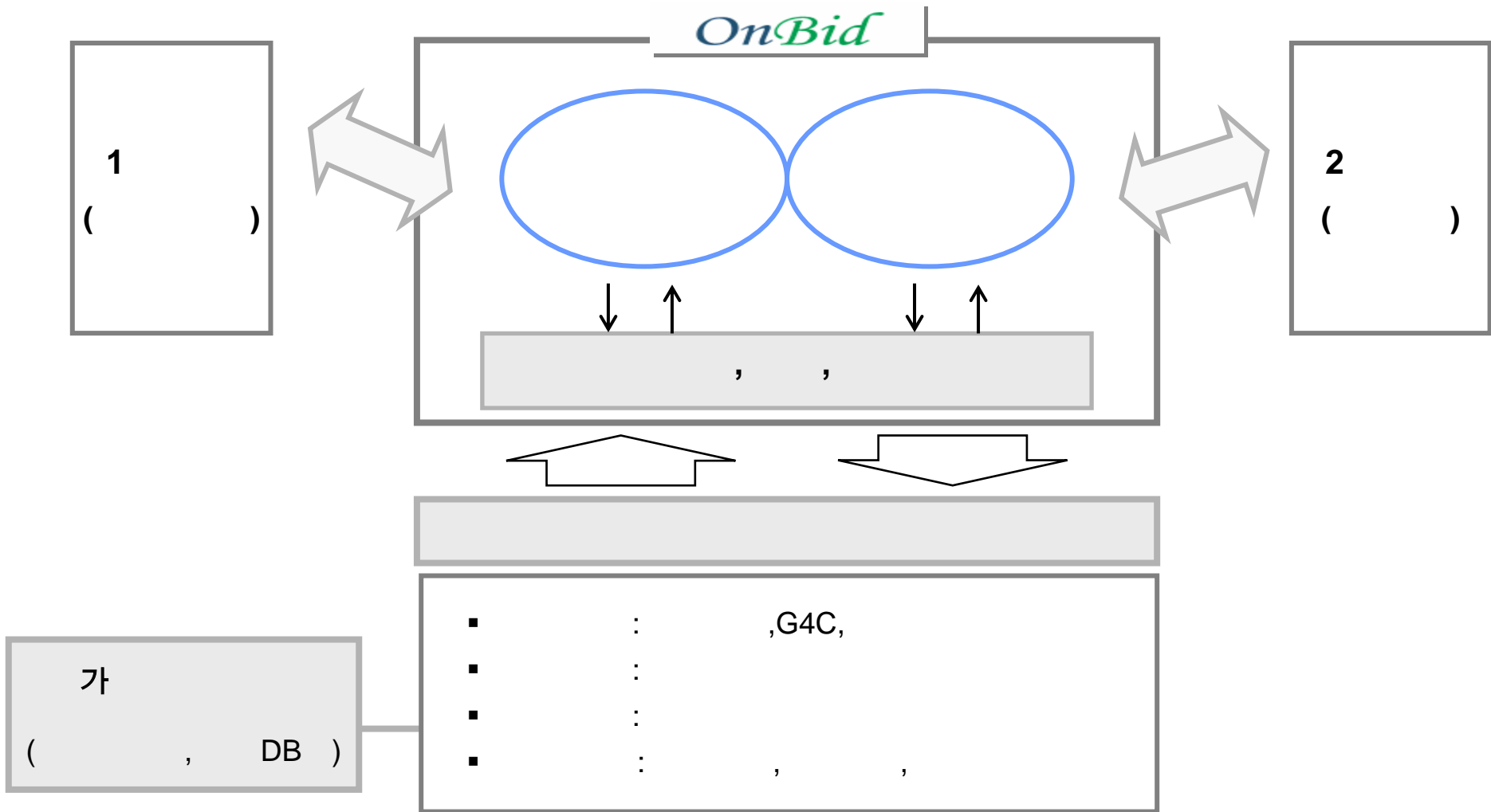

2.

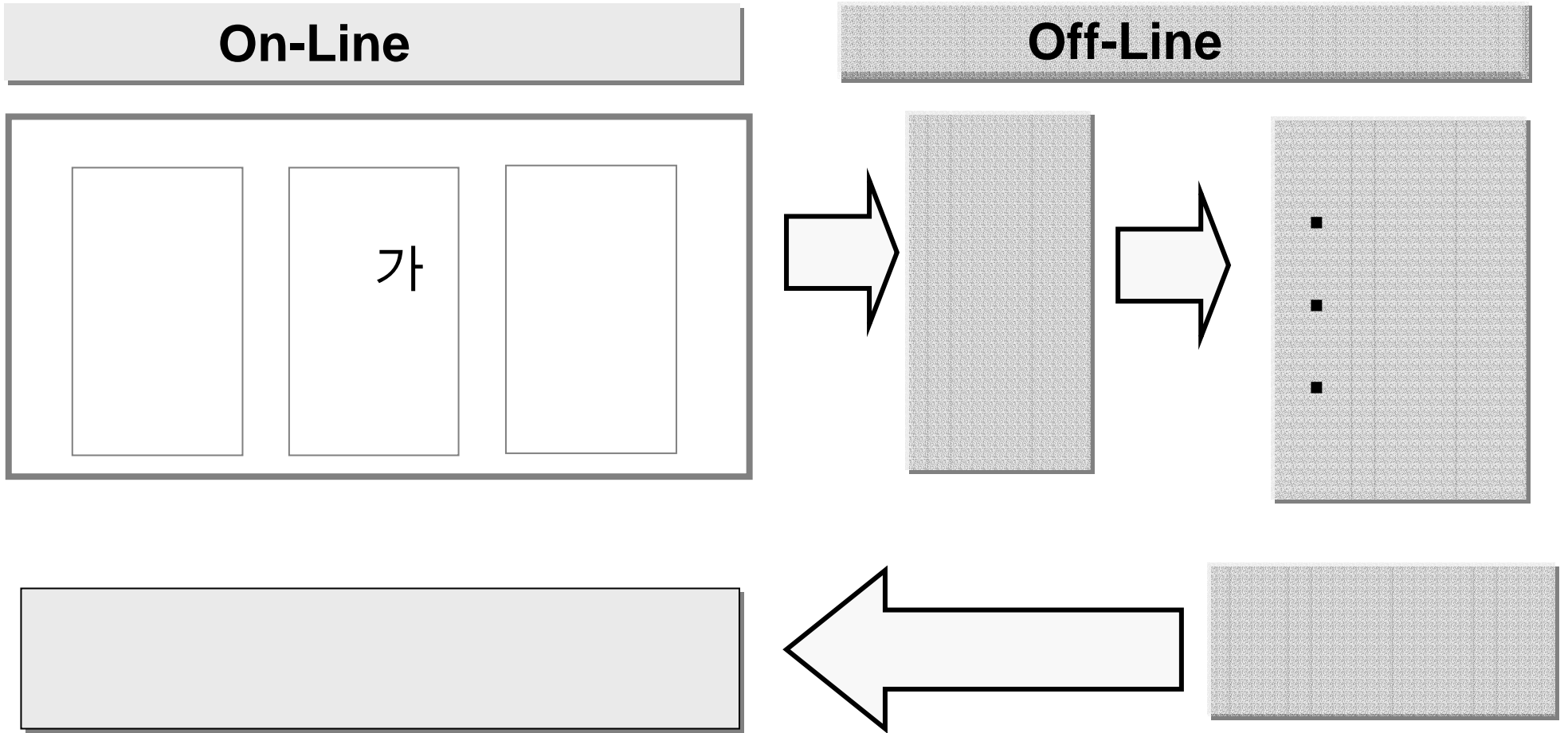

2.

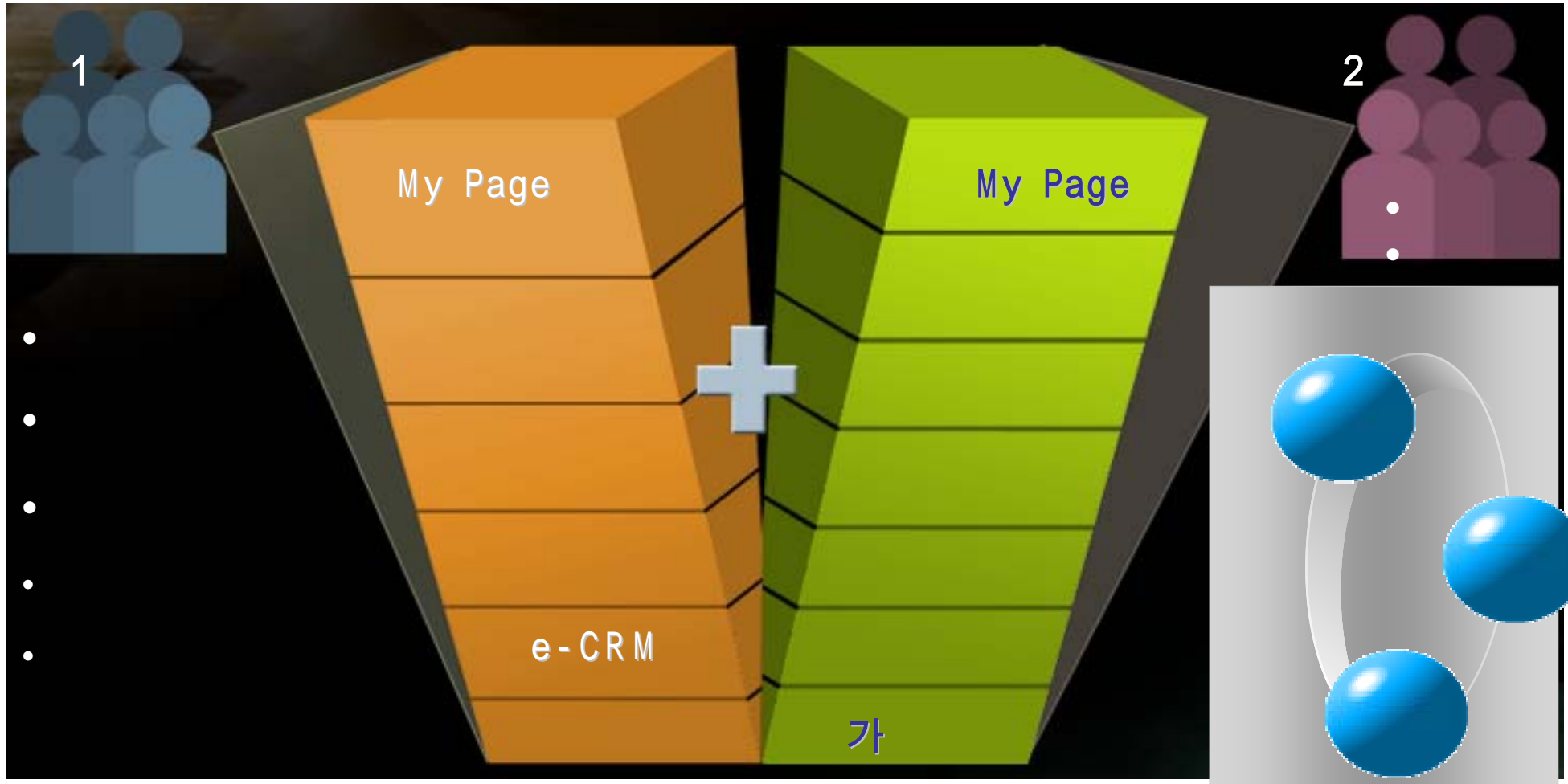

2.

☐ G2B

| | G2B(가) | () |
|--|---|--|
| | <ul style="list-style-type: none"> 가 , , , , , ; 主- | <ul style="list-style-type: none"> 1 ; () 2 ; (主- •) |
| | <ul style="list-style-type: none"> , , | <ul style="list-style-type: none"> , , () |
| | <ul style="list-style-type: none"> ; , , | <ul style="list-style-type: none"> ; () |
| | <ul style="list-style-type: none"> | <ul style="list-style-type: none"> |
| | <ul style="list-style-type: none"> KAMCO G2B | <ul style="list-style-type: none"> 가 |

2.

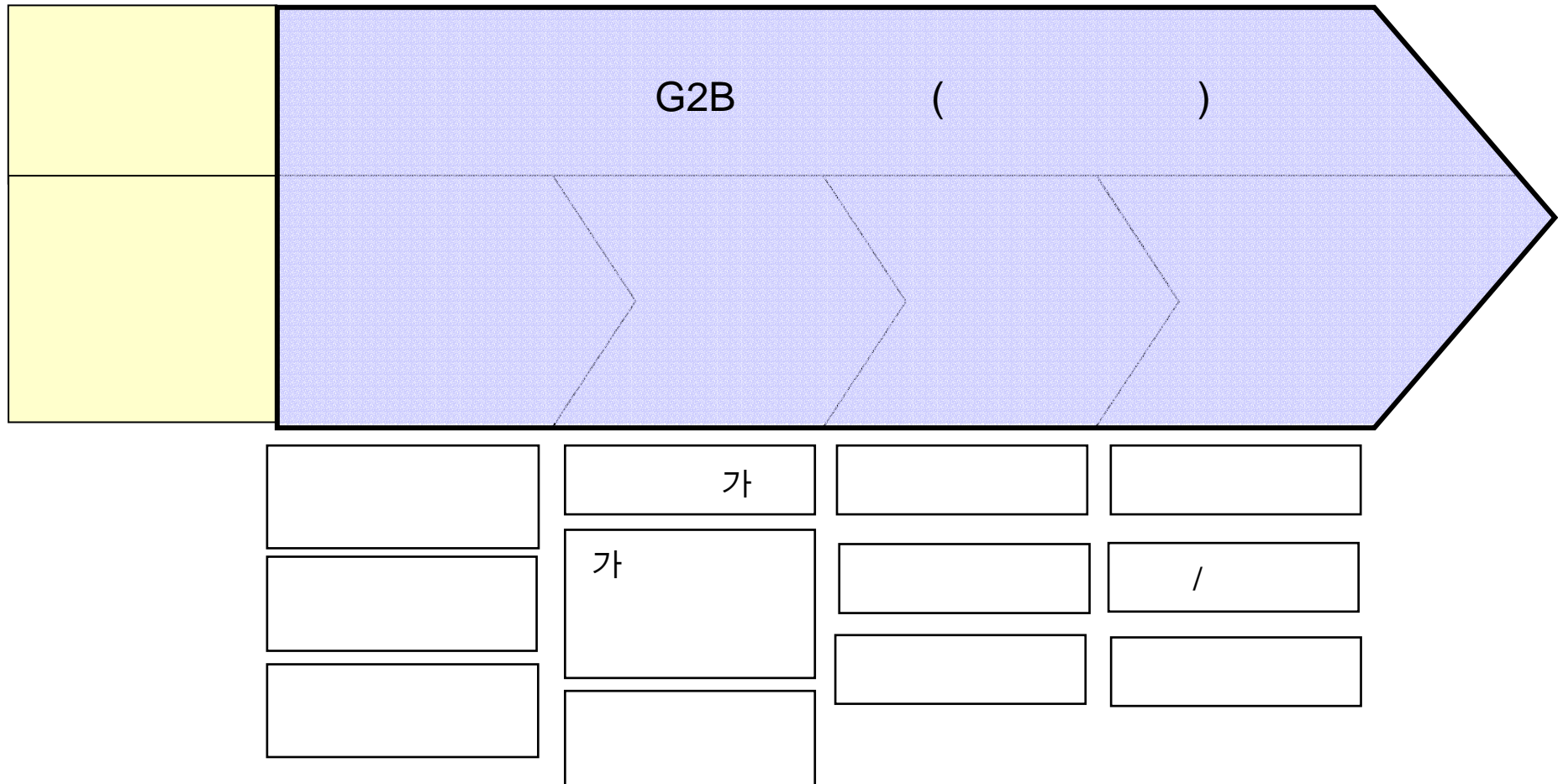

2.

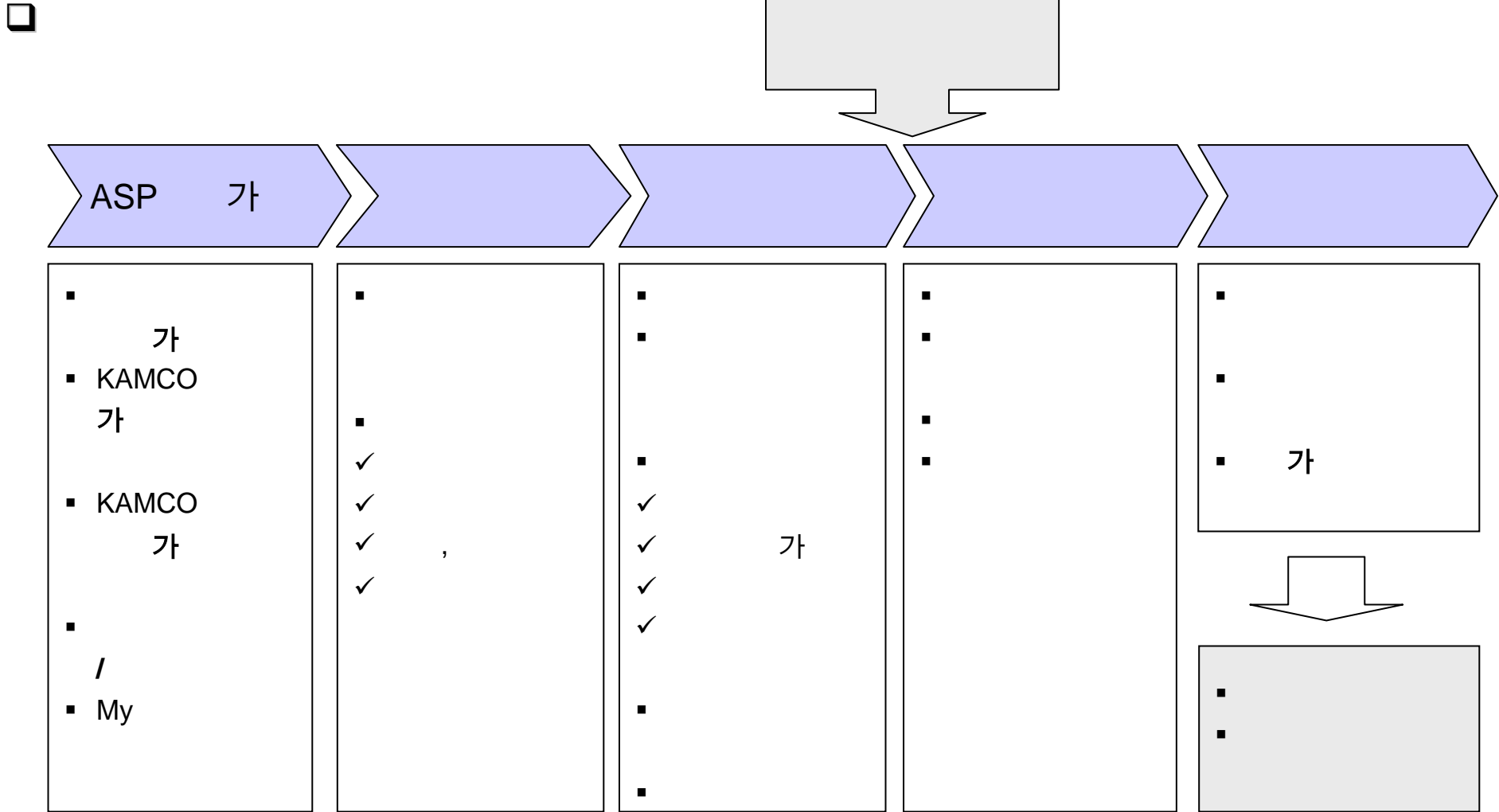

2.

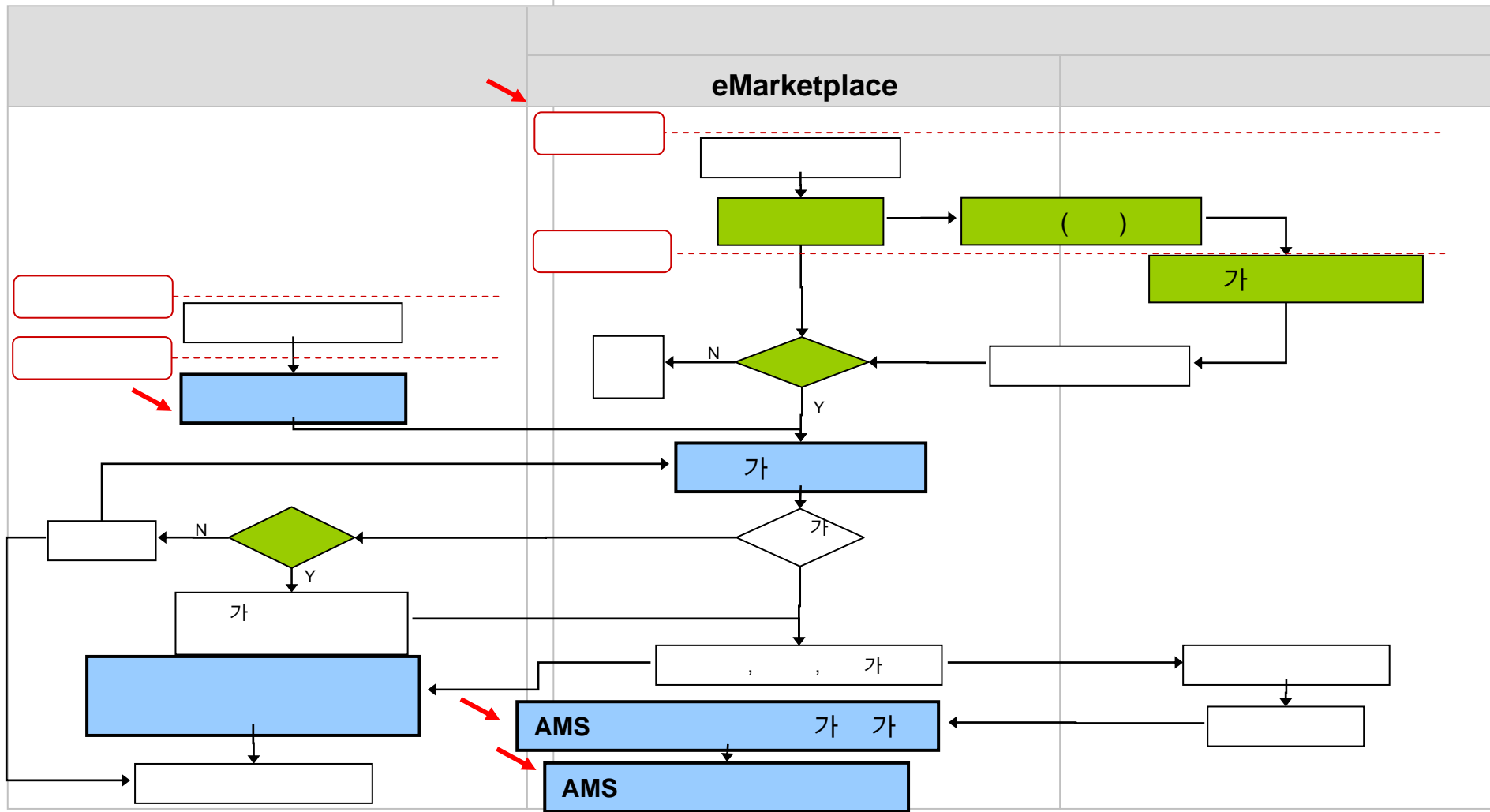

2.

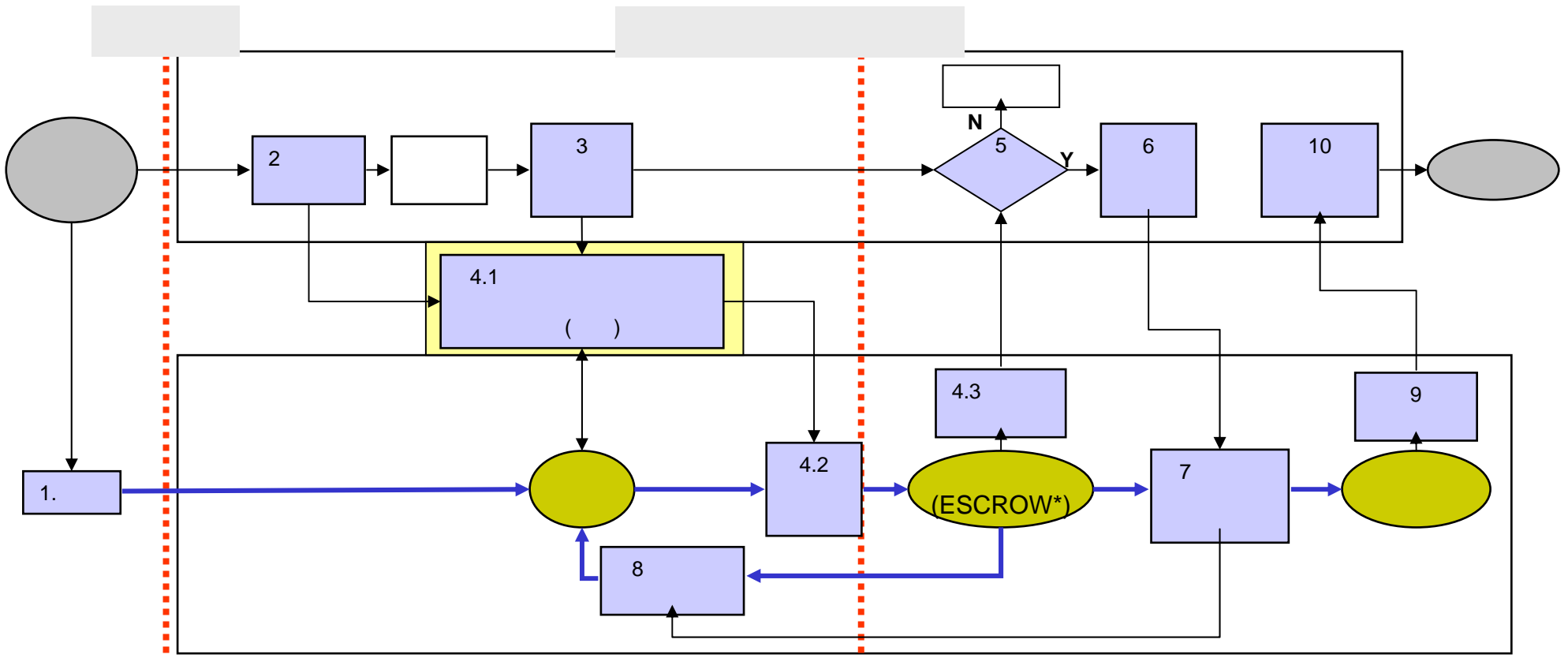

*ESCROW:

3.



off-line

,



.



.

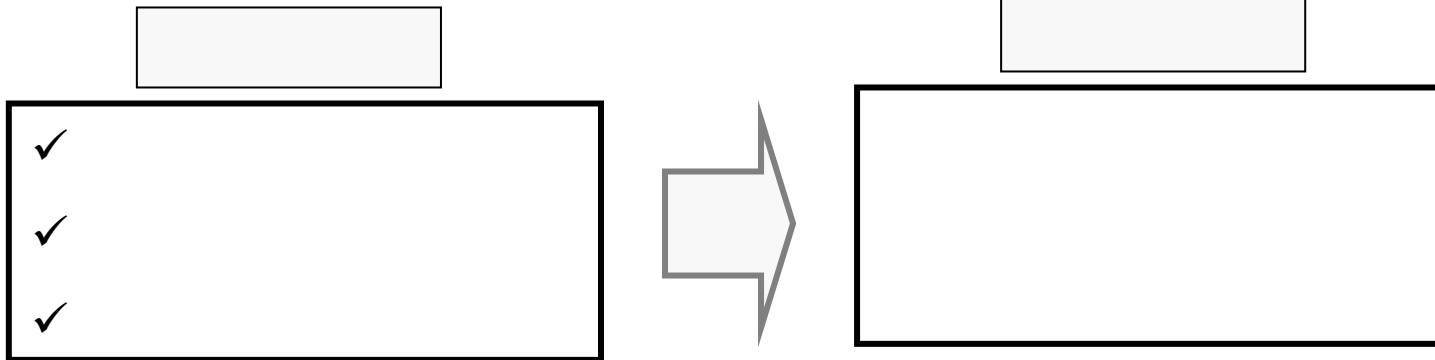

3.



-
-

:

가

,



-

:

,

,

,



-
-
-

4.



가



가 가

○ 가가 / , 가 가 가

○ 가 (NAFIS)

5.



✓ 24 Hour a day, 365 a year, Save money



✓ Marketing



○

-

가?

-

,

가?

-

○

○

,

○

,

○

,

,

○

○

5.



- :
○



- 가
○
○

6.



- , , 가

-



-

- EDI

-

- 가

-

-

6.



7.



-
-



-



- One - Stop
-

8.

가 21 가

가